

# SINGLE AND DOUBLE REEL UNWINDER



easy to install



reduced maintenance



robustness and reliability



made in Svecom



certificate

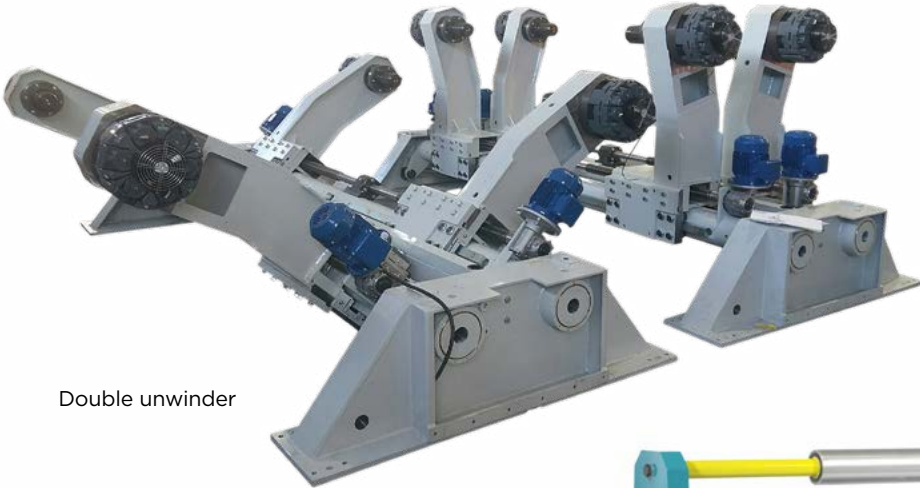

Double unwinder

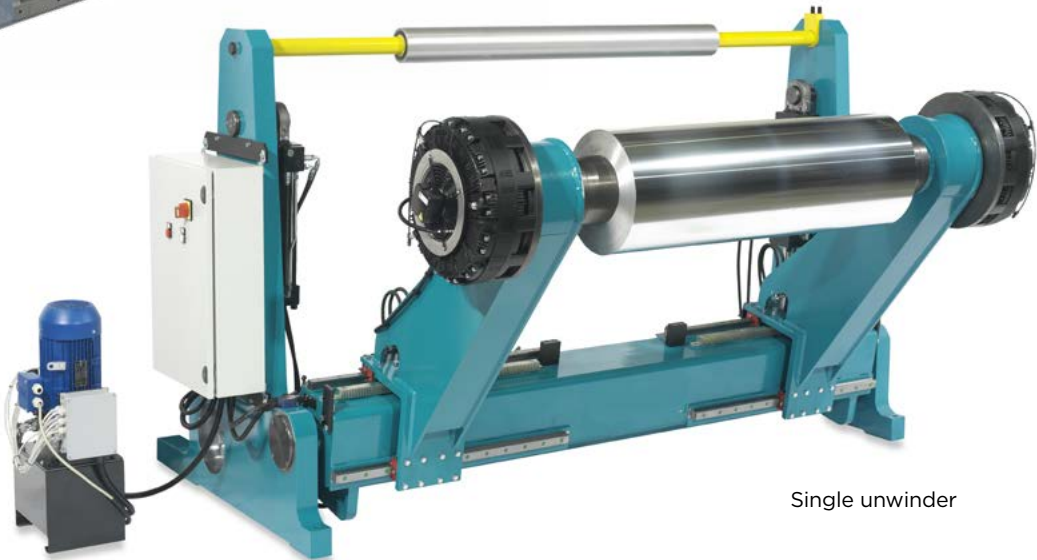

Single unwinder

**The unwinder for reels has been designed to unwind reels of different diameters and widths, according to the required specifications.**

The unwinder for reels is composed of a fixed part equipped with feet for floor fixing and one / two mobile upright (s) on which the two / four moving arms are installed which support the reel at both ends.

Opening and closing arms by means of hydraulic motors and rack with sliding on ball runners. The arms are independent, it is in fact possible to move them without worrying about the immediate centering of the reel. The centering itself will take place regardless of the initial position of the reel. Arms lifting by means of hydraulic pistons controlled by a hydraulic

unit positioned on the ground. Complete with expandable pneumatic chuck with leaves, adjustable return roller for better material wrapping. Pneumatic or mechanical brakes self-ventilated on both sides. Braking control is regulated by a signal from the slitting machines.

Electrical components, electrical limit switches located on the machine, electrical panel on the machine. Manual controls on remote push-button panel.

**OPTIONAL**

- Double base with movement on wheels that allow lateral translation of 3 100 mm continuously
- Addition of complementary rollers
- Electrical panel with push button

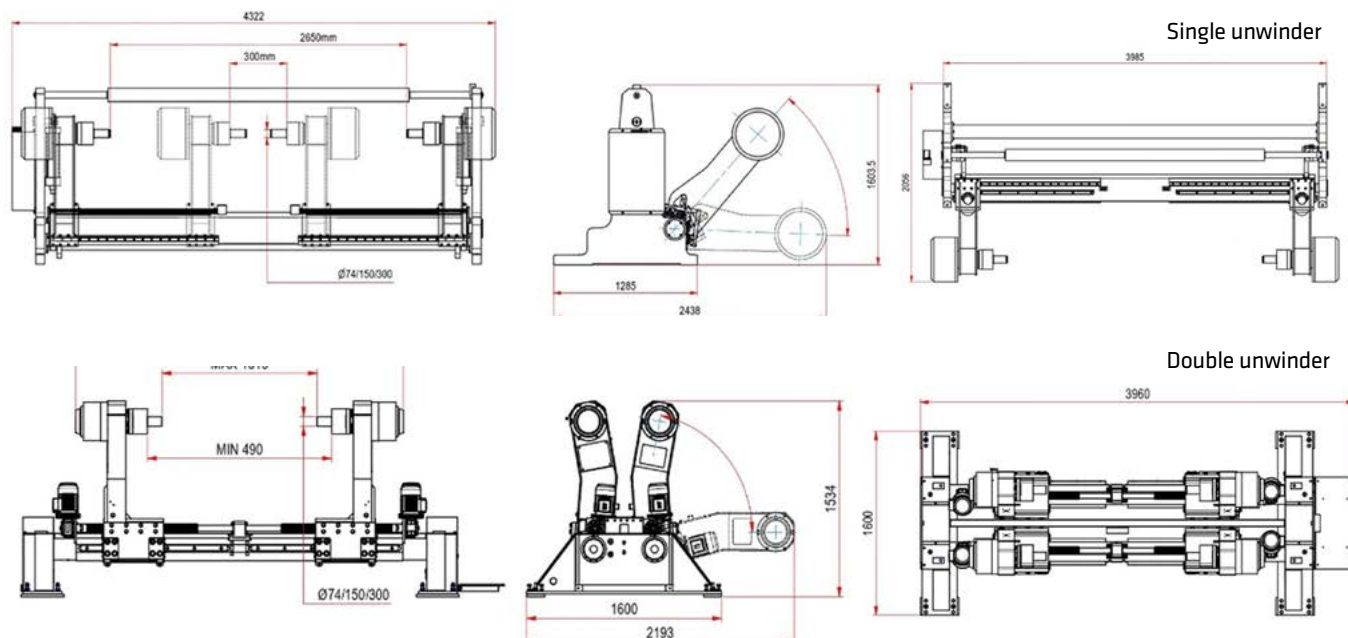

DATA SHEET*	
SUPPLY VOLTAGE	220/380 V - 50/60 Hz
REEL LENGTH	from 300 to 2.650 mm (single unwinder) from 490 to 1.610 mm (double unwinder)
INTERNAL CORE DIAMETER	74-150-300 mm
REEL WEIGHT	max. 3.000 Kg
REEL EXTERNAL DIAMETER	max. 2.000 mm (single unwinder) max. 1.200 mm (double unwinder)
UNWINDING SPEED	400 m/min. (single unwinder) 150 m/min. (double unwinder)

\*The technical data are purely indicative. Contact Svecom - P.E. for customized requests